

Cam Clutch /
Cam Follower
Free wheel clutch

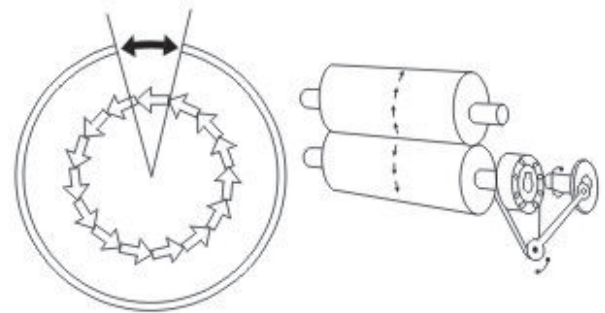

● Standard sprag cam clutch construction

● Indexing application

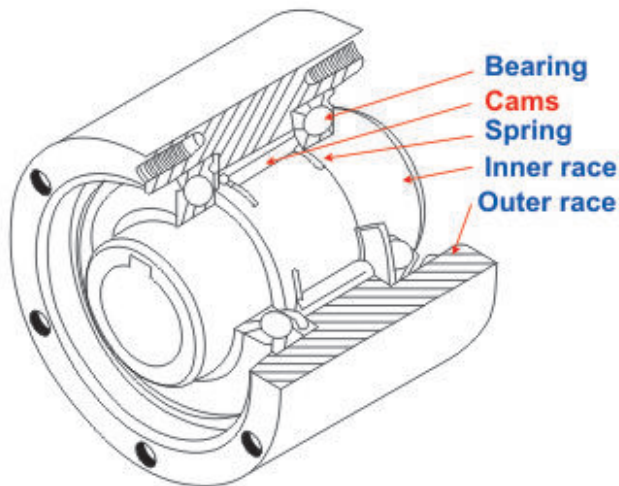

Indexing

Other sub Parts : Plate, Snap ring, Oil seal, Plug and Seal washer

All Cam Clutches consist very few parts and have simple construction.

● For General Application

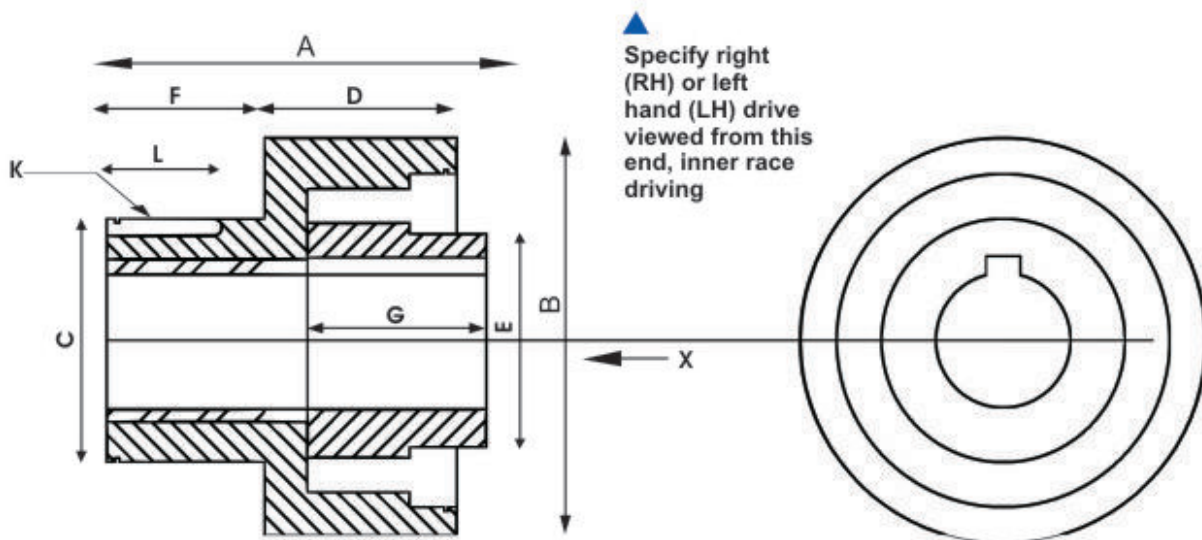

Dimensions and Capacities

Dimensions in mm

Model	Max. Torque (N-m)	Max. Overrunning (r/min.)		Max. indexing (cycle/min.)	Stock Bore Size		A	B	C (h7)	D	E	F	G	Outer Race Keyway		Weight (kg)	Lubrication Filler Plug Size x Pitch
		Inner Race	Outer Race		K	L											
PB 3	29.4	1,800	900	150	10	4 x 1.5	50	50	23	22	25	21	25.7	4 x 2.5	16	0.23	M6 x P1.0
PB 5	147	1,800	900	150	16	5 x 2.0	70	60	32	32	35	25	38.8	5 x 3.0	20	0.58	M6 x P1.0
PB 6	382	1,500	800	150	20	5 x 2.0	82	73	38	38	37	33	41.0	5 x 3.0	27	1.1	M6 x P1.0
PB 8	568	1,200	650	150	25	7 x 3.0	85	83	45	40	45	33	42.0	7 x 4.0	27	1.6	M6 x P1.0
PB 10	1104	1,000	400	150	31.5	10 x 3.5	90	95	57	45	55	37	42.0	10 x 4.5	28	2.5	M6 x P1.0
PB 12	1800	800	300	150	40	10 x 3.5	100	113	65	50	60	37	53.5	10 x 4.5	29	3.6	M6 x P1.0
PB 14	2110	700	300	150	45	12 x 3.5	112	133	75	54	76	41	57.3	12 x 4.5	30	6.0	M6 x P1.0

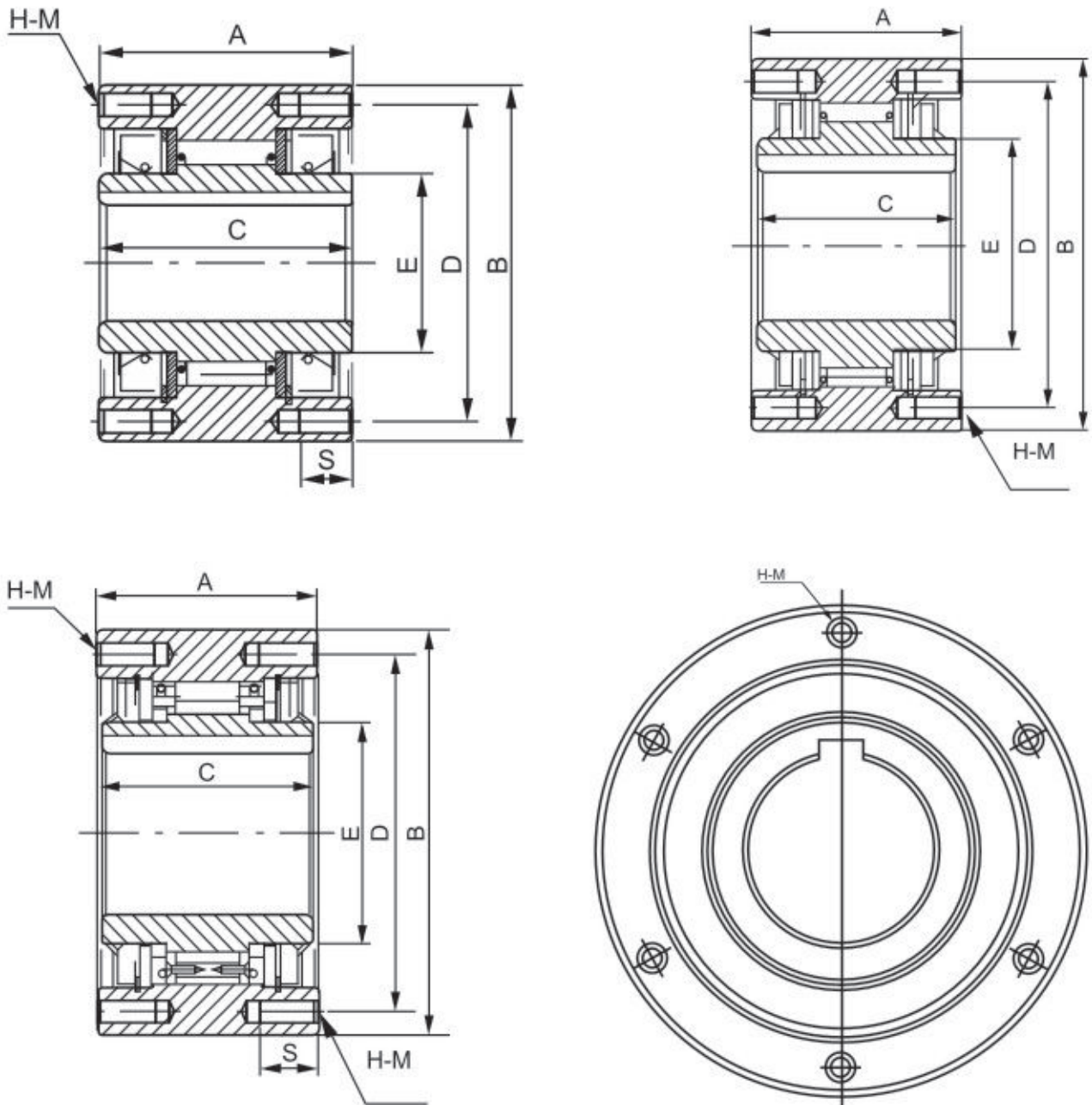

Model	Torque N.m	Tsubaki Torque Rating	Width A	OD - B	C	PCD - D	bolt size & No
RS - 30	350	294	64	90	64	80	M 6 X 1.0 - 4
RS - 50	2505	784	67	125	67	110	M8 X 1.25 - 4
RS - 65	3267	1570	90	160	85	140	M10 X 1.5 - 6
RS - 75	3969	2450	90	170	85	150	M10 X 1.5 - 6
RS - 85	7150	5880	115	210	110	185	M12 X 1.75 - 6
RS - 95	8500	7840	115	230	110	200	M14 X 2.0 - 6
RS - 110	10800	10800	115	270	110	220	M16 X 2.0 - 6
RS - 135	15700	15700	135	320	130	280	M16 X 2.0 - 6

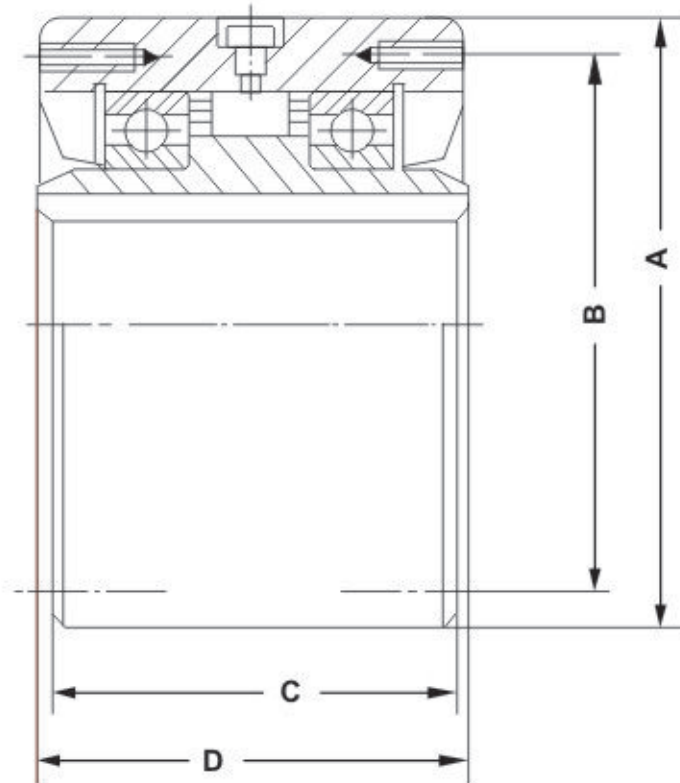

Model	Torque N.m	Max bore	key way	OD-A	PCD-B	C	WIDTH -D	Mounting Holes
SF 300	210	19	4.76 x 2.38	76.2	66.7	60.3	63.5	1/4"
SF 400	413	22.2	4.76 x 2.38	88.9	73	66.7	69.9	5/16"
SF 500	1172	33.2	6.33 x 2.38	107.95	92.1	85.7	88.9	5/16"
SF 600	2070	50.8	12.7 x 4.76	136.53	120.7	92.9	95.3	5/16"
SF 700	5517	74.8	15.8 x 3.16	180.92	158.8	123.8	127	3/8"
SF 750	9379	87.3	19.5 x 4.76	222.22	177.8	149.2	152.4	1/2"
SF 800	15862	112.7	25.4 x 6.35	253.98	227	149.2	152.4	1/2"
SF 900	22758	138.1	25.4 x 6.35	304.76	247.65	158.7	161.9	5/8"
SF 1000	29655	163.5	31.75 x 9.53	380.96	298.45	171.4	177.8	5/8"

leading edge technocrat

204/205-Tower-A, Vraj Venu Complex, Samta Gotri Road,
Gotri, Vadodara – 390021. Gujarat, INDIA.

☎ +91-265-6503797, 📞 +91-9824734703

✉ gmpatel@leading-edge.in